



# 2660 SERIES

## PRESSURE/VACUUM (HIGH FLOW)

### BASE MODELS

#### AC Voltage

**2660E48XNTLSXX**

(115/60/1)

**2660N48XNTLSXX**

(220-240/50/60/1)

**2660S48XNTLSXX**

(100/50/60/1)

### CUSTOM CONFIGURED OPTIONS

#### AC Voltage

- Stroke (Flow and/or pressure)
- Pump restart
- Head port thread
- Foot tap thread
- Electrical cord
- Piston seal
- Fan guard
- Protective coating

### AFTERMARKET SERVICE KITS

SK2660

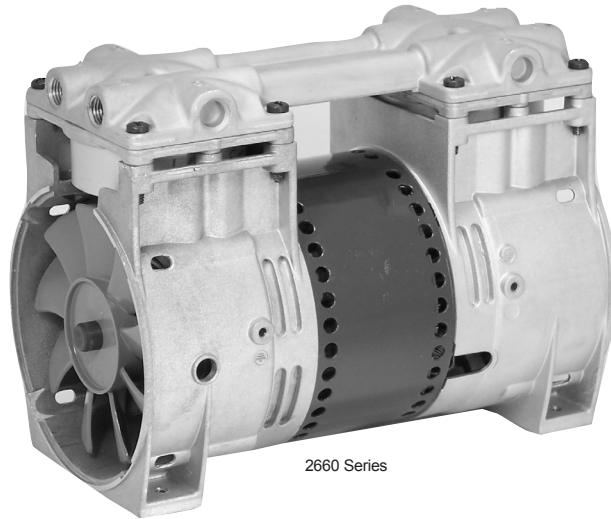

2660 Series

### FEATURES (BENEFITS)

- Oil-less operation (Clean air stream, less maintenance)
- Permanently lubricated bearings (Optimum life)
- Stainless steel valves (Optimum life, consistent performance, corrosion resistance)
- Die-cast aluminum components (Strong, lightweight, durable)
- Dynamically balanced (Low operating vibration)
- Proven WOB-L® technology (Optimum life)
- Monolithic head (Fewer parts, eliminates potential leak paths)
- Field service capability (Maximum return on investment)
- Thermally protected motor (Fail-safe operation)
- Designed and tested per Agency standards (Fail-safe operation)
- Inlet filter/exhaust muffler (Quiet, clean operation)
- RoHS compliant (Green, eco-friendly)

Declaration documentation for applicable models available upon request

**Qualified OEM designers should  
consult factory for purchase or custom configurations**

- 920-457-4891 or [td.usa@gardnerdenver.com](mailto:td.usa@gardnerdenver.com)
- Minimum order quantities may apply

Thomas Division is an ISO 9001 registered company

**THOMAS**  
by Gardner Denver



# WOB-L<sup>®</sup> 2660 Series Base Models



by Gardner Denver

**Max. Flow** 4.6 cfm (130.3 l/min)

**Max. pressure** 45 psi (3.1 bar)

**Max. vacuum** 92% local barometer

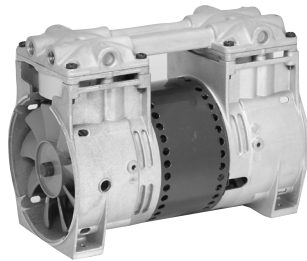

Note: Supplied capacitor mounted remotely.

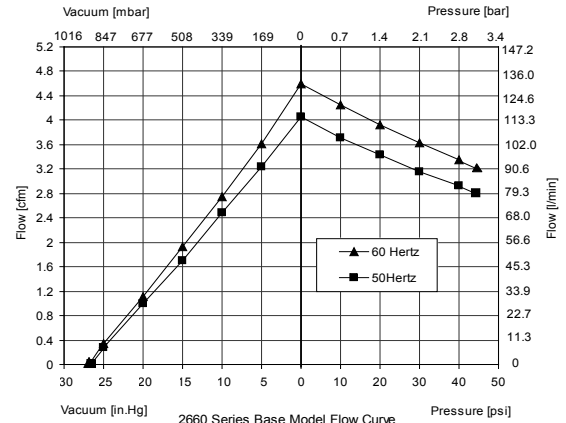

See Performance Data for base model maximum operating pressures  
Consult factory for custom configured stroke options

Model Number	2660E48XNTLSXX	2660N48XNTLSXX	2660S48XNTLSXX
<b>Performance Data</b>			
Head configuration	Pressure/vacuum parallel flow	Pressure/vacuum parallel flow	Pressure/vacuum parallel flow
Stroke	0.48 in (12.2 mm)	0.48 in (12.2 mm)	0.48 in (12.2 mm)
Nominal voltage/frequency	115V 60Hz	220-240V 50/60Hz	100V 50/60Hz
Maximum open air flow	4.6 cfm (130.3 l/min)	4.0/4.6 cfm (113.3/130.3 l/min)	4.0/4.6 cfm (113.3/130.3 l/min)
Maximum operating pressure	40 psi (2.8 bar)	45/40 psi (3.1/2.8 bar)	25/20 psi (1.7/1.4 bar)
Current at rated pressure	5.3A	2.5/2.7A	4.5/4.4A
Power at rated pressure	608W	523/604W	421/432W
Speed at rated pressure	1675 rpm	1409/1682 rpm	1436/1695 rpm
Maximum pressure restart	Consult factory	Consult factory	Consult factory
Maximum vacuum	92% local barometer	92% local barometer	92% local barometer
Maximum vacuum restart	Consult factory	Consult factory	Consult factory
<b>Electrical Data</b>			
Motor type [Capacitance]	P.S.C. [25 µF]	P.S.C. [15 µF]	P.S.C. [25 µF]
Motor in-rush current	18.0A	9.3/8.3A	15.0/14.5A
Motor insulation class	B	B	B
Thermal switch [Open temperature]	Yes [293°F (145°C)]	Yes [248°F (120°C)]	Yes [293°F (145°C)]
Line lead wire color, gauge	Brown(hot), blue(neutral), 18 AWG	Brown(hot), blue(neutral), 18 AWG	Brown(hot), blue(neutral), 18AWG
Capacitor lead wire color, gauge	Black, black, 18 AWG	Red, red, 18 AWG	Black, black, 18 AWG
<b>General Data</b>			
Operating ambient air temperature	50° to 104°F (10° to 40°C)	50° to 104°F (10° to 40°C)	50° to 104°F (10° to 40°C)
Safety certification	cUL	TUV	None
Net weight	17.6 lbs (8.0 kg)	17.1 lbs (7.8 kg)	17.6 lbs (8.0 kg)

## Product Dimensions

Dual Dimensions: in[mm]

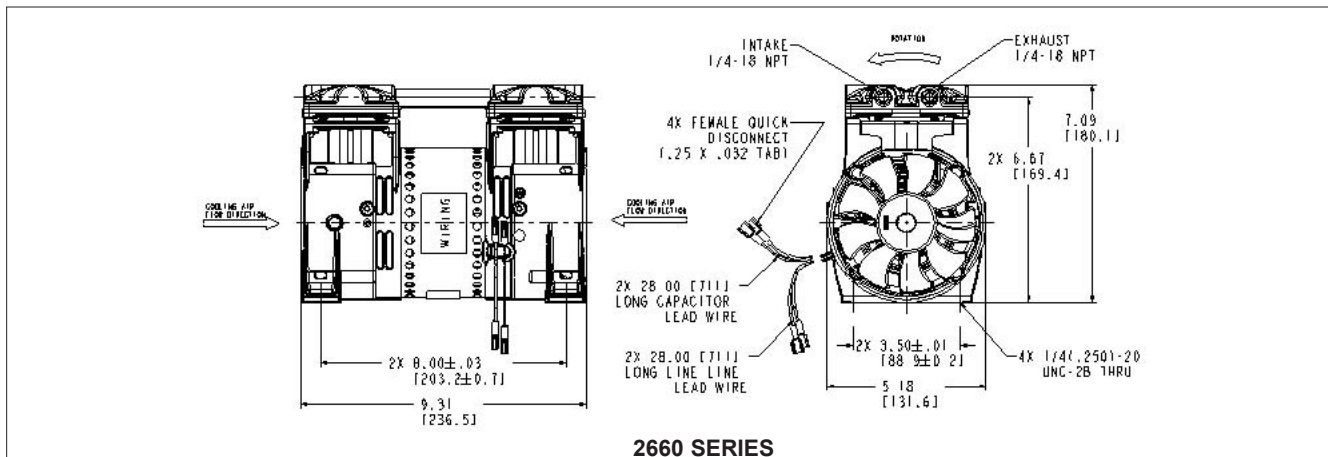

### 2660 SERIES

## 2660 SERIES

©2011 Gardner Denver Thomas, Inc.  
All rights reserved.  
Form No. 850-4009 03/16

The information presented in this material is based on technical data and test results of nominal units. It is believed to be accurate and reliable and is offered as an aid to help in the selection of Thomas Division products. It is the responsibility of the user to determine the suitability of the product for its intended use and the user assumes all risk and liability whatsoever in connection therewith. Thomas Division does not warrant, guarantee or assume any obligation or liability in connection with this information. **NOTE:** Models pictured are representative of the series and do not represent a specific model number. Consult factory for detailed physical description.

**Thomas Division**  
1419 Illinois Ave  
Sheboygan, WI 53081 USA  
Phone: 920-457-4891  
Fax: 920-451-4276  
www.gd-thomas.com